

Evaluation Kit for MP400FC

INTRODUCTION

The EK65 Evaluation kit is designed to provide a convenient way to breadboard and evaluate design ideas for the MP400FC power operational amplifier. The evaluation board is pre-wired for all required external components. The evaluation board has been laid out and labeled to easily configure the high voltage operational amplifier in a non-inverting differential configuration for single supply operation using the MP400FC boost supply (Refer to applications note 21). However, the evaluation board is flexible enough to analyze a multitude of standard or proprietary circuit configurations.

BEFORE YOU GET STARTED

- Please read this data sheet in it's entirety before starting to construct your evaluation board.
- All Apex amplifiers should be handled using proper ESD precautions.
- Do not change connections while the circuit is powered.
- Initially set all power supplies to the minimum operating voltage allowed in the device data sheet.
- The MP400FC is a high voltage amplifier with an integrated switch mode power supply. Though the input voltage will be 50V or less, the MP400FC can generate voltages greater then 350V. The high generated voltage will be present on the evaluation board. Caution must be used when working with the evaluation board.

FIGURE 1 - EK65 Schematic

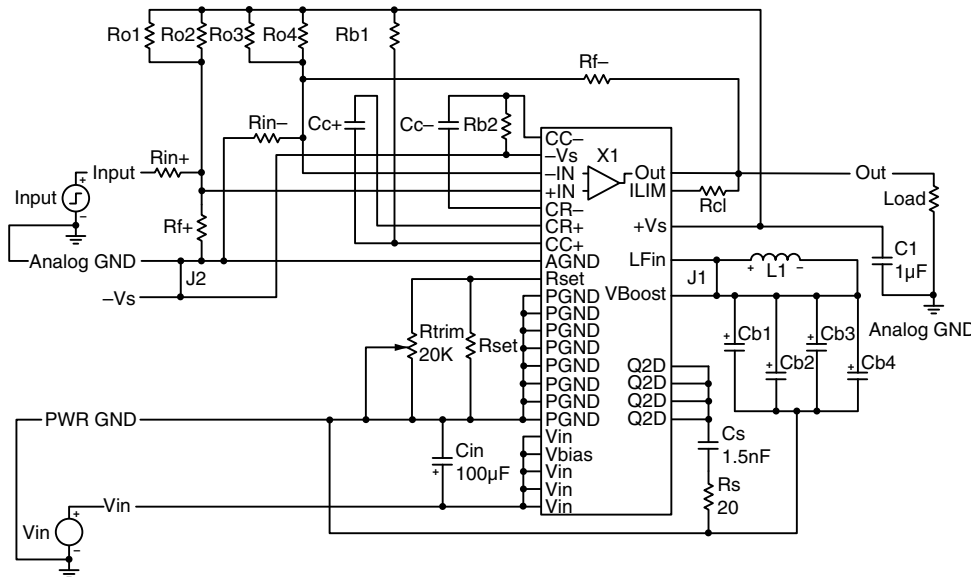

PARTS LIST (Included with kit)

Ref.	Apex P/N	Description/Vendor	Qty.
N/C	HS26	Heat Sink	1
N/C	MS11	Strip of 30 cage jacks	2
N/C	EVAL65	PC board	1
N/C	93505A430	Hex standoff, 4-40x1/4	4
N/C	90272A105	Screw, 4-40x3/16	4
BJ1-6	571-0100	Banana Jack, PC	6
BN1	146510CJ	BNC, PC mount	1
C1	ZX7R105KTL	Cap. 1 µF, 500V	1
		Novacap ST2225B105K501LLXW	
Cb1	EKM401VSN121MP30S	Cap. 120µF, 400V	1
Rtrim	T93YA203KT20	Trim Pot, 20K	1

REQUIRED COMPONENTS (Not included with kit)

Ref.	Description
Cin	Capacitor, Low ESR electrolytic, 100µF or greater with voltage rating greater than the anticipated input voltage.
Cb1-4	Cboost capacitor, Low ESR electrolytic with voltage rating greater than the anticipated boost voltage. Refer to the MP400FC data sheet for Cboost selection. One 120µF, 400V electrolytic capacitor (Cb1) is supplied with the kit and is adequate for most applications. The value of Cboost is selected to meet required boost supply ripple voltage specifications for the application and to minimize switching noise on the boost supply. Cboost will be as large as reasonably possible, in the range of 100µF to 500µF. An area on the evaluation board large enough for 4 parallel 22mm diameter capacitors is provided. This allows maximum flexibility in the select of the capacitors for Cboost. Capacitors with snap in terminals should still be soldered to the evaluation board to minimize resistance.
Rset	Boost voltage programming resistor. Refer to the MP400FC data sheet for calculation of Rset. Select a higher standard value resistor and use Rtrim (supplied) to calibrate the boost voltage to the exact desired value. Alternatively, Rtrim can be used alone for a fully adjustable boost supply.
Rcl	Operational amplifier current limit resistor. Refer to the MP400FC data sheet for selection of the current limit resistor.

OPTIONAL COMPONENTS (Not included with kit)

Ref.	Description
Lf	Boost supply filter inductor. The MP400FC includes a 47µH inductor in series with the LFin pin and the +Vs supply of the high voltage op amp. This on board inductor forms a 2 pole LC filter with C1 and an on board parallel 0.1µF capacitor. Combined with a properly selected Cboost, the high voltage DC boost voltage will be sufficiently clean for most applications. However an external inductor between Vboost and LFin, or Vboost and +Vs can be used for additional filtering of the Boost supply voltage if necessary. Addition capacitance can be added to the filter between +Vs and AGND.
Cs, Rs	Also useful for boost supply filtering. These components form an RC snubber from drain to source of the boost supply MOSFET switch. This snubber will help reduce or eliminate overshoot and ringing of the MOSFET switch at switch turn-off that can appear on the boost supply voltage. The component values shown on the schematic are adequate for most applications but can be adjusted for your specific application. The power in the resistor can be estimated by the formula $PD = F \cdot C \cdot V^2$, where $F = 100 \text{ KHz}$ of the switching supply $C = \text{the value of } Cs$ $V = \text{the anticipated } V_{\text{boost}} \text{ voltage.}$ Rs must be non-inductive. MP900 and MP9000 series resistors from Caddock Electronics or equivalent resistors can be used. Rs may require a heat sink such as Apex part number HS28 or HS23. Mounting holes for a heat sink are provided on the evaluation board that will accommodate either of these heat sinks.
Cc+, Cc-	High voltage op amp compensation capacitors. Refer to the MP400FC data sheet for component selection.
Ro1-4, Rf+, Rf-, Ri+, Ri-	Op amp gain setting and input bias resistors used for the single supply differential configuration described in applications note 21. Appendix A of apps note 21 provides a procedure for the design of the differential configuration and selection of these components. Apps note 21 can be down loaded from the Apex web site. The locations on the board for Ro1-4 are large enough for up to a 3W resistor. 3W 1% resistor style CPF from Vishay Dale are widely available through distribution. RN60, RN65 or RN70 style 1/2W 1% resistors can be used for the other resistors.

ASSEMBLY

During assembly, refer to Figure 1, Figure 2 and the MP400FC data sheet.

- Note that the silk screen side of the circuit board is labeled as the “component side”. The other side of the circuit board will be referred to in these instructions as the “DUT side” of the board.
- The Analog ground AGND and power ground PGND are clearly labeled on the boards. All components for the on board boost supply are referenced to PGND, and all components for the high voltage op amp are ref-

erenced to AGND. The board has been designed to keep switching currents from the boost supply out of the analog ground. AGND and PGND are common at only one point on the MP400, and are not connected at all on the evaluation board. To avoid ground loops and switching currents in the analog ground, avoid making any connections between these two ground references at the board level. Note the dashed line on the component side of the board showing the dividing line between the analog ground side of the board and the power ground side.

3. Cut one of the MS11 strips to a length of 20 cage jacks and the other MS11 to a length of 22 cage jacks. From the DUT side of the board, insert the strips into the appropriate row of holes for the DUT pins. On the component side of the board, solder all cage jacks having solder pads (pins 3, 5, 7, 9, 11, and 16 have no solder pads). Make sure the cage jacks are fully seated before soldering. Be careful that solder does not flow into the cage jacks. Remove the unsoldered cage jacks with the carrier strip segments.
4. Solder the ZX7R105KTL surface mount capacitor at C1 on the component side of the board.
5. Insert BJ1 – BJ6 from the component side of the board as desired for your application. The banana jack locations are labeled with the associated input or output. BJ1 is provided for use as an input for a negative bias supply voltage to $-V_s$ for bipolar supply operation. It also could be used as an alternative to the BNC connector for the input signal or other inputs to your application circuit. If you do not anticipate using BJ1 it should be left off. Solder the banana jacks to the board from the DUT side.
6. Insert the BNC connector BN1 from the component side of the board. Solder to the board from the DUT side. BN1 can be left off if you do not intend to use it for an input to your circuit.
7. Select and insert Rset from the component side of the board at the location shown near pin 34 of the DUT and solder from the DUT side. Rtrim may be installed for calibration of the boost supply voltage or as an alternative to Rset. If installed as shown on the board with the knob toward Cin, a CW turn will increase Vboost and a CCW turn will decrease Vboost.
8. Select and insert Rcl from the component side at the location marked for Rcl between pins 1 and 2 of the DUT. Solder from the DUT side.
9. Select and insert other components as required for your application. J1 is required to supply Vboost to the high voltage op amp through the on board $47\mu\text{H}$ filter inductor. Vboost can be jumpered to the $+V_s$ pin if the filter is not to be used. Alternatives are to replace the jumper with an external inductor between the Vboost pin and LFin or $+V_s$. A filter capacitor can be added between $+V_s$ and AGND. You may want to start with J1 as shown and try other options as you are evaluating your design.
10. J2 is required to connect the high voltage op amp $-V_s$ to AGND for single supply operation. If an external negative supply voltage will be used, replace J2 with a high quality ceramic bypass capacitor of at least $1\mu\text{F}$, and jumper $-V_s$ to BJ1. BJ1 can be used to connect the negative supply to the evaluation board.
11. Rin+ and Rin- when installed as marked on the component side of the board near BJ1 and BN1, will configure

FIGURE 2 - EVAL65 PCB Layout

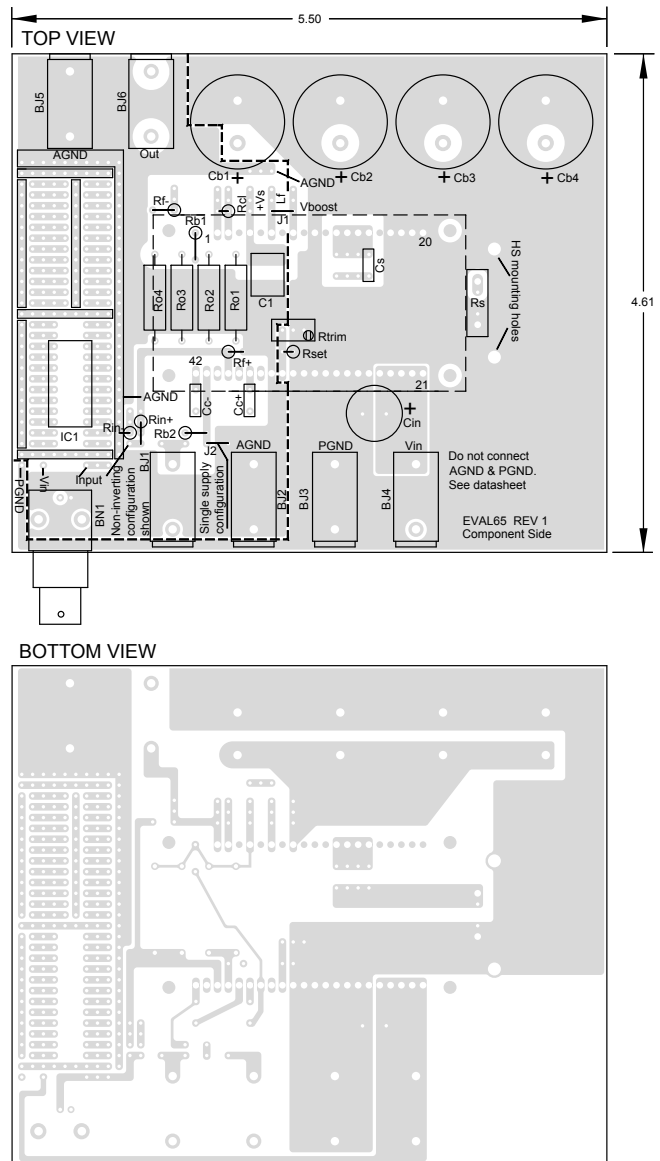

- the op amp in the non-inverting configuration with Rin- to AGND and Rin+ to the input BNC. For an inverting configuration, rotate Rin+ to AGND and Rin- to the input.
12. If the snubber Cs and Rs will be used, select and insert the components at the location marked near DUT pins 12 – 15. If the calculated power dissipation indicates that a heat sink is required for Rs, install it with Rs. Cs and Rs can be installed after you have started evaluating your design if they are found to be needed.
 13. Vin power can be supplied to your circuitry in the breadboard area. There are two pads located below the breadboard area near BN1. One labeled Vin and one labeled PGND can be jumpered into your circuit as needed.
 14. Mount the electrolytic capacitors at Cin, and Cboost from the component side of the PCB. Match the polarity markings on the PCB. Solder from the DUT side of the PCB. Be sure to fill the holes with solder.
 15. Apply a thin, uniform layer of thermal grease to the back side of the MP400FC. Position the amplifier over the mounting holes of the HS26 heat sink. Firmly push the amplifier onto the heat sink while slightly rotating the amplifier back and forth, ending with the mounting holes of the amplifier over the mounting holes in the heat sink.
 16. Attach the amplifier to the heat sink with the supplied 4-40 x 1/4" male-female hex spacer. Tightened with a hex nut driver. Make the hex spacers snug but do not over tighten as this provides no benefit and may break the hardware.
 17. Carefully lower the PCB assemblies onto the heat sink/amplifier assembly until the pins of the amplifier engage in and are fully seated in the cage jacks aligning the mounting holes in the PCB to the hex spacers. Use the supplied 4-40 x 3/16" screws to attach the PCB assembly to the hex spacers.
 18. Hook up power and signals as necessary. The amplifier is now ready for testing.

FIGURE 3 - EK65 Assembly





CONTACTING CIRRUS LOGIC SUPPORT

For all Apex Precision Power product questions and inquiries, call toll free 800-546-2739 in North America.

For inquiries via email, please contact tucson.support@cirrus.com.

International customers can also request support by contacting their local Cirrus Logic Sales Representative.

To find the one nearest to you, go to www.cirrus.com

IMPORTANT NOTICE

Cirrus Logic, Inc. and its subsidiaries ("Cirrus") believe that the information contained in this document is accurate and reliable. However, the information is subject to change without notice and is provided "AS IS" without warranty of any kind (express or implied). Customers are advised to obtain the latest version of relevant information to verify, before placing orders, that information being relied on is current and complete. All products are sold subject to the terms and conditions of sale supplied at the time of order acknowledgment, including those pertaining to warranty, indemnification, and limitation of liability. No responsibility is assumed by Cirrus for the use of this information, including use of this information as the basis for manufacture or sale of any items, or for infringement of patents or other rights of third parties. This document is the property of Cirrus and by furnishing this information, Cirrus grants no license, express or implied under any patents, mask work rights, copyrights, trademarks, trade secrets or other intellectual property rights. Cirrus owns the copyrights associated with the information contained herein and gives consent for copies to be made of the information only for use within your organization with respect to Cirrus integrated circuits or other products of Cirrus. This consent does not extend to other copying such as copying for general distribution, advertising or promotional purposes, or for creating any work for resale.

CERTAIN APPLICATIONS USING SEMICONDUCTOR PRODUCTS MAY INVOLVE POTENTIAL RISKS OF DEATH, PERSONAL INJURY, OR SEVERE PROPERTY OR ENVIRONMENTAL DAMAGE ("CRITICAL APPLICATIONS"). CIRRUS PRODUCTS ARE NOT DESIGNED, AUTHORIZED OR WARRANTED TO BE SUITABLE FOR USE IN PRODUCTS SURGICALLY IMPLANTED INTO THE BODY, AUTOMOTIVE SAFETY OR SECURITY DEVICES, LIFE SUPPORT PRODUCTS OR OTHER CRITICAL APPLICATIONS. INCLUSION OF CIRRUS PRODUCTS IN SUCH APPLICATIONS IS UNDERSTOOD TO BE FULLY AT THE CUSTOMER'S RISK AND CIRRUS DISCLAIMS AND MAKES NO WARRANTY, EXPRESS, STATUTORY OR IMPLIED, INCLUDING THE IMPLIED WARRANTIES OF MERCHANTABILITY AND FITNESS FOR PARTICULAR PURPOSE, WITH REGARD TO ANY CIRRUS PRODUCT THAT IS USED IN SUCH A MANNER. IF THE CUSTOMER OR CUSTOMER'S CUSTOMER USES OR PERMITS THE USE OF CIRRUS PRODUCTS IN CRITICAL APPLICATIONS, CUSTOMER AGREES, BY SUCH USE, TO FULLY INDEMNIFY CIRRUS, ITS OFFICERS, DIRECTORS, EMPLOYEES, DISTRIBUTORS AND OTHER AGENTS FROM ANY AND ALL LIABILITY, INCLUDING ATTORNEYS' FEES AND COSTS, THAT MAY RESULT FROM OR ARISE IN CONNECTION WITH THESE USES.

Cirrus Logic, Cirrus, and the Cirrus Logic logo designs, Apex and Apex Precision Power are trademarks of Cirrus Logic, Inc. All other brand and product names in this document may be trademarks or service marks of their respective owners.